

INCH-POUND

A-A-59178A
12 October 2004
SUPERSEDING
A-A-59178
9 April 1998

COMMERCIAL ITEM DESCRIPTION

NIPPLE, ELECTRICAL TERMINAL

The General Services Administration has authorized the use of this commercial item description for all federal agencies.

1. **SCOPE.** This commercial item description (CID) establishes the government acquisition requirements for silicone rubber electrical terminal nipples used to protect electrical terminals from the elements.
2. **CLASSIFICATION.** The nipples shall be classified by the sizes shown in table I. The size to be furnished shall be as specified (see 7.3(b)).

Table I. Electrical terminal sizes and dimensions.

Size code	A Length	B Height	C Thickness	D Diameter	E Diameter	F Diameter	G Diameter	H Diameter
1	1.38	0.56	0.06	0.40	0.63	0.16	0.41	0.76
2	2.50	1.00	0.06	0.56	0.82	0.31	0.56	0.95
3	2.50	1.00	0.06	0.56	0.82	0.43	0.68	0.95
4	2.50	1.00	0.06	0.56	0.82	0.56	0.82	0.95

Note: All dimensions are in inches. Tolerances are ± 0.02 .

Beneficial comments, recommendations, additions, deletions, clarifications, etc. and any data that may improve this document should be sent to: STDZNMGT@dla.mil or Defense Supply Center Richmond (DSCR), ATTN: DSCR-VEB, 8000 Jefferson Davis Highway, Richmond, VA 23297-5616.

AMSC N/A

FSC 5975

DISTRIBUTION STATEMENT A. Approved for public release; distribution is unlimited.

3. SALIENT CHARACTERISTICS

3.1 General requirements. The electrical terminal nipple shall be manufactured from silicone rubber to the dimensions shown in figure 1. The silicone rubber shall conform to the requirements of Society of Automotive Engineers (SAE) AMS 3302, "Silicone Rubber, General Purpose, 50 Durometer" (DoD adopted). The manufacturer's identification and part number shall be legibly molded on each nipple.

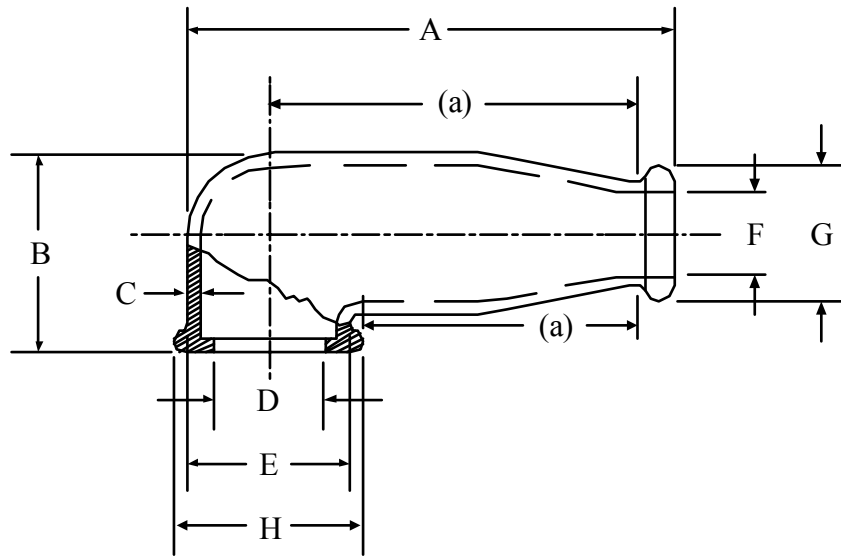

Note: (a) Contour within these limits may vary to suit individual manufacturer's design.

FIGURE 1. Dimensional requirements.

4. REGULATORY REQUIREMENTS

4.1 Recovered materials. The offeror/contractor is encouraged to use recovered materials to the maximum extent practicable, in accordance with paragraph 23.403 of the Federal Acquisition Regulation (FAR).

5. PRODUCT CONFORMANCE PROVISIONS

5.1 Product conformance. The products provided shall meet the salient characteristics of this CID, conform to the producer's own drawings, specifications, standards, and quality assurance practices, and be the same product offered for sale in the commercial marketplace. The government reserves the right to require proof of such conformance.

5.2 Market acceptability. The product offered must have been previously sold either to the government or on the commercial market.

6. PACKAGING

6.1 Preservation, packing, and marking. Preservation, packing, and marking shall be specified in the acquisition order (see 7.3(c)).

7. NOTES

7.1 Part or identification number (PIN). The following PIN procedure is for government purposes and does not constitute a requirement for the contractor or manufacturer.

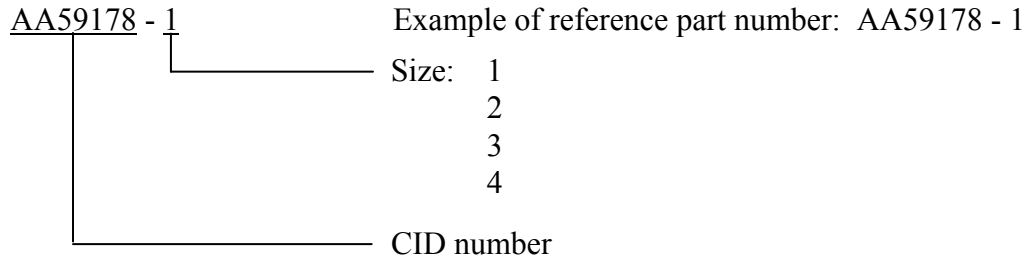

7.2 Sources of documents.

7.2.1 FAR. Copies of FAR may be obtained from the Superintendent of Documents, P.O. Box 371954, Pittsburgh, PA 15250-7954. Electronic copies of FAR documents may be obtained from <http://www.arnet.gov/far/>.

7.2.2 SAE standards. Copies of SAE standards may be obtained from SAE International, 400 Commonwealth Drive, Warrendale, PA 15096-0001. Electronic copies of SAE standards may be obtained from <http://www.sae.org/>.

7.3 Ordering data. The acquisition order should specify the following:

- a. CID document number, revision, and CID PIN.
- b. Size of nipple required (see 2).
- c. Preservation, packing, and marking (see 6.1).

7.4 Subject term (key word) listing.

silicone
rubber

A-A-59178A

MILITARY INTERESTS:

Custodians:

Navy - AS

Air Force - 11

Review Activities:

Navy - MC

Air Force - 99

CIVIL AGENCY
COORDINATING ACTIVITY:

GSA - FSS

Preparing Activity:

DLA - GS2

(Project 5975-1361)